

Threading machine for tubes up to 2” Instruction Manual



162120

EC DECLARATION OF CONFORMITY**VIRAX 39, Quai de Marne - B.P. 197 - 51206 ÉPERNAY Cedex - FRANCE****Declares that the machine described below****162120 VIRAX Workshop Threading machine 1/2 to 2"****Complies with the requirements of the following Directives:**

2006/95/EC relating to electrical equipment designed for use within certain voltage limits. (Low voltage)

2004/108/EC "ElectroMagnetic Compatibility" relating to electromagnetic compatibility and repealing

Directive 89/336/EEC

98/37/EC relating to "machinery",

and to relevant national legislation transposing these directives.

Complies with harmonized European standards :**EN 55014-1****EN 55022****Epernay August 24th, 2009.****Eric MIN***Quality Manager***CE 09**

EN

162120 Threading Machine for tubes up to 2”

Instruction manual

Thank you for purchasing the threading machine and for showing confidence in our company.

Virax, a major manufacturer and retailer of tools for the Sanitary, Environmental engineering and Roofing trades, supplies the tools you use in your everyday work:

Virax, showing off your talent.



This documentation has been produced with care to enable you to use the machine to its best and in complete safety. We strongly recommend you to read this instruction manual carefully before using the machine and to keep it within easy reach of the machine.

Sommaire

Safety instructions	5
General safety instructions.....	5
Choice of tool.....	5
Maintenance and storage	5
Safety instructions for the user	5
Safety instructions relating to the work area.....	6
Prohibited uses	6
Handling and working instructions	7
Transporting the machine	7
Instructions relating to the machine electrical power supply.....	7
Instructions relating to your protection and the protection of those around you	7
Maintenance instructions	9
Storage instructions.....	10
General description of the 162120 threading machine	11
Basic functions	11
Diameters of tubes which can be threaded	11
Tubes which can be threaded, cut or reamed	11
Available thread types	12
Setting the length and outside diameter of the thread	12
Option of installing a groover	12
General characteristics.....	13
Moving and setting up the machine	14
Moving by lifting equipment	14
Moving manually.....	15
Moving using a trolley.....	15
Slope of the machine.....	17
Positioning a tube	18
Positioning short tubes	18
Cutting a tube	19
Reaming a tube.....	20
Threading a tube.....	21
Producing a thread	21
Producing double threads on short tubes (nipples or reels)	22
Using the 2" die head (Part no. 162151).....	25
Installing the head	25
Adjusting the threading diameter	26
Adjusting the thread outside diameter	27
Adjusting the thread length.....	27

Using the 1/4 – 3/8" head (part no. 162150)	28
Installing the head	28
Adjusting the threading diameter	29
Adjusting the thread outside diameter	29
Manually opening the dies	29
Replacing the dies	30
Replacing dies on the automatic opening 2" head	30
Replacing dies for the 1/4 – 3/8" head	32
Maintenance operations	34
Cleaning the oil system	34
Replacing the motor brushes	35
Taking up shaft slack	36
Replacing the cutter wheel	36
Replacing the tube cutter	37
Replacing the reaming cone	38
Replacing the reamer	38
Replacing the front chuck jaws	39
Replacing the front chuck jaw holders	41
Diagnostics and fault fixes	44
Machine operating problems	44
Thread cutting problems	45
Tube cutting problems	47
Reaming problems	47
Exploded views	48
Exploded view of the frame	48
Exploded view of the motor and the oil pump	49
Exploded view of the transmission	50
Exploded view of the saddle	51
Exploded view of the automatic opening 2" die head	52
Exploded view of the 1/4" - 3/8" die head	53
Exploded view of the tube cutter	54
Exploded view of the reamer	55
Components of a nipple holder	56

Safety instructions

The Virax 162120 threading machine is an electro-mechanical machine which presents certain hazards. It is therefore important to obey the following instructions to avoid causing yourself or others possible serious injuries or lesions.

General safety instructions

Choice of tool

- Use a suitable tool. Do not use low-power adaptable tools or devices for carrying out heavy work. Do not use tools for purposes other than those for which they have been designed.

Maintenance and storage

- Store your tools in a safe place. Unused tools must be stored in a dry, closed location out of the reach of children.
- Maintain your tools carefully. Maintain your own tools so that you can work better and in greater safety. Observe maintenance indications as well as those relating to the changing of accessories. Keep handles dry and free of oil and grease.
- Check whether the tool is damaged. Before using the tool, always carefully check that all the parts are operating correctly. Check that the parts move correctly, that they do not seize and that other parts are not damaged. All the components must be installed correctly and fulfil the conditions needed to ensure that the tool is in perfect working order. All safety devices, switches or other damaged or defective parts must be appropriately repaired or replaced by a qualified technician.
- **Warning!** Be sure to use the tool and its accessories in accordance with the safety instructions. Consider the range of options for the tool taking into account the working conditions and the task to be carried out. It can be dangerous to use the tool for tasks for which it is not intended.
- This tool complies with current safety regulations. All repairs must be carried out by qualified professionals using original spare parts, failing which the tool may become dangerous to use and the warranty will be nullified.

Safety instructions for the user

- Keep children away. Do not allow other people to touch the tool; keep them away from your working area.
- Wear appropriate working clothes. Do not wear loose clothing or jewellery; they could be caught in the moving parts.
- When working in the open air, you are recommended to wear rubber gloves and shoes with nonslip soles. If you have long hair, tie it back with a hair net.
- Do not increase your range. Avoid adopting a posture which you find tiring; make sure you have a firm footing and always maintain your balance.
- Always concentrate. Look at your work, use your common sense and do not use the tool when you are tired.

Safety instructions relating to the work area

- Keep your work area tidy. Untidiness increases the risk of an accident.
- Take into account the environment around your work area. Do not expose electric power tools to the rain. Do not use electric power tools in a damp or wet environment.
- Make sure the work area is well lit. Do not use electric power tools in the neighbourhood of inflammable liquids or gases.

Prohibited uses

- **The machine is not intended for tightening or loosening joints.**
You may be tempted to use the power of the machine for tightening or loosening joints. Doing this is prohibited as the force of the motor is much greater than the force exerted by the hand holding the joint whether directly or using a spanner. When loosening, you risk fracturing your hand or forearm or having the spanner thrown at you or one of your colleagues. (Moreover, when loosening, if the joint has not been released, you will subject the motor to a force which may damage it.)
- **The machine is not a winch.**
You may be tempted to use the force of the motor to raise or lower loads. This use is prohibited as the machine could topple over and jettison its load. (Moreover, you may damage the motor).

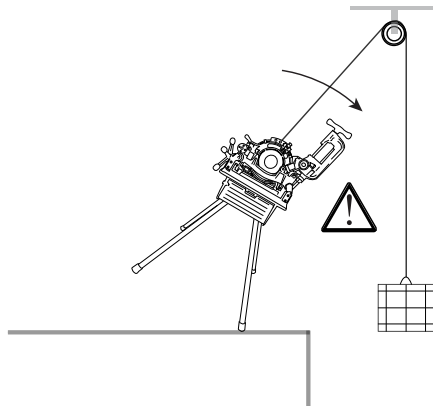

- **The machine is not intended for coating the threads with sealing paste.**
As the paste is naturally applied by hand, this exposes the operator to the risk of being cut.

Important: Virax may in no respect be held liable for accidents which occur arising from the machine being used for purposes other than those for which it was intended.

- **Do not use tools other than those designed for use with the machine.**
Only the cutting, reaming and threading tools designed for the machine may be mounted on the machine.

Important: Virax may in no respect be held liable for accidents which occur arising from the use of tools other than those specifically intended for use with the 162120.

Handling and working instructions

Transporting the machine



- The machine weighs about 60 kg. So two people are needed to carry it. Two handles are provided at either end of the frame for this purpose. To move the machine using a hoist or crane, proceed as indicated in page 14. In addition, a trolley has been especially designed for transporting the machine. (This is described on page 15).

Instructions relating to the machine electrical power supply.



- The machine must be provided with a 230V electrical power supply.
- The plug and any extension lead must have a grounding pin connected to a ground connection in the workshop.
- Do not pull the machine by its power cable. (This is not a rope!). Likewise, do not disconnect the machine by pulling on the cable.

Instructions relating to your protection and the protection of those around you

- It is essential to place the tube on one or more pipe holders, also called benches. (Virax part numbers: pipe holder without feet: 161100 ; pipe holder with feet: 161110).

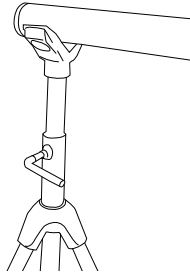

If the free length of the tube behind the machine is too long (typically more than 1m empty), you risk the tube starting to oscillate (which you may not realize in time as your attention will be on the tube being machined) which then causes the machine to become unstable causing it to topple towards you.

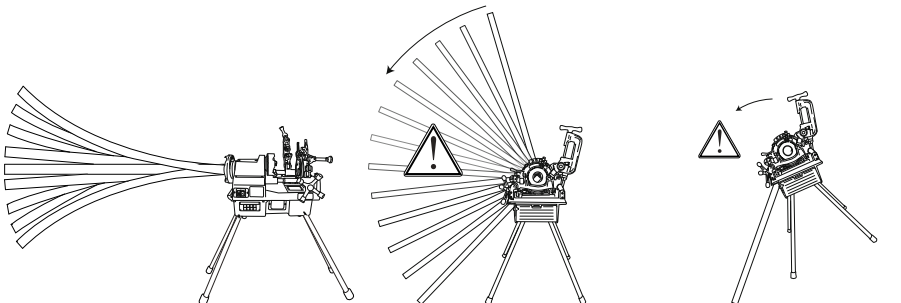



- **Do not wear a tie, scarf, pendants, loose clothing, chain bracelets, rings etc. or wear your hair long...** any of which could be caught by the rotating parts of the machine.



- **Wear protective goggles** to protect your eyes from oil spatter and, most importantly, from any metal turnings which are thrown up. In the case of oil spatter, wash your eyes copiously with water and consult an ophthalmic doctor if you experience any problems with your vision. If a metal turning is thrown up, do not try to remove it or have it removed by anyone else but consult a specialist service immediately.



- **It is essential to wear a helmet with ear defenders.**

In compliance with standard EN 61029-1 (refer to the standard published in your language) and standard ISO 3744, laboratory tests have given the following results:

Acoustic power level:	LwA = 92 dB(A)
Acoustic pressure at the user's ears:	LpA = 84 dB(A)
	LpMaxPeak < 130 db(C)



- **Be careful not to cut yourself** on contact with sharp items, in particular: cutter wheel, thread dies, reaming cone, internal edges of the tube.



- **Wear gloves for handling metal turnings:** these can cause bad, fine and deep cuts.
- **Wear gloves** if you are allergic to lubrication oil.



- **Pay attention to crushing hazards,** in particular when lowering the tube cutter, the die head or the reamer and when the saddle is moving.



- **Wait for the motor to stop** before carrying out any work.
- **Disconnect the machine** when carrying out assembling, dismantling and cleaning operations in order to guard against the risks of the machine being accidentally started up: you or one of your work colleagues could accidentally step on the control pedal or press the start button while your hands are in the machine.

Warning: The machine is protected against accidental starting by a relay. After the electrical power is cut, you can only start the machine by pressing the start button. You must not **under any circumstances short circuit the start button** under the pretext of «helping you with your work».

Likewise, you **must not use a machine whose start or stop button** is not working.



- Before starting the machine, **check there are no tools** (Allen key, screwdriver, open-end wrench, etc.) **on the machine**: when the motor starts, the tool may be thrown towards you or one of your colleagues.
- **Check that no unauthorized person** is in the vicinity of the machine.



- **Stop the machine immediately** if you notice anything unusual about the way it is running: motor slowing down or stalling, sparks, smoke, burning smell, vibrations, etc.
Refer to the “Diagnostic and fault fixing” chapter in this manual. If the indications given do not enable you to resolve the problem, contact Virax or one of its representatives.



- **Do not work on the machine** if you do not feel well: drowsiness, fever, feeling very tired. Many accidents in the workplace are due to a lack of vigilance.

Maintenance instructions

- **Regularly check the state of the machine.** Identify, as much as possible, any cracks, overlarge play etc. and in general any anomaly.
- **Regularly change the four dies** of the die head, especially when the turnings become less whole and more broken up.
- **Regularly check the oil level.** You **must not** thread your tubes without a sufficient oil flow.
- You **must** use one of the oils supplied by Virax as all mechanical tests have been carried out using these oils.

Oils which can be used:

- Oil for cutting steel tubes
Possible packaging:
 - 1 L drum (part no. 110101)
 - 5 L drum (part no. 110105)
 - 1 case of 12 x 1L drums (part no. 110112)
 - 20 L drum (part no. 110120)
 - 500 ml aerosol (part no. 110200)
 - Case of 12 x 500 ml aerosols (part no. 110202)
- Oil for cutting stainless steel tubes
Possible packaging:
 - 5 L drum (part no. 110505)
 - 1 case of 4 x 1L drums (part no. 110506)
- Synthetic cutting oil
Complies with sanitary standard DVGW (identification no. DW-0201AT2541).
Possible packaging:
 - 5 L drum (part no. 110605)

Important: The warranty will be invalidated if any oil is used which has not been supplied by Virax.

- Besides the tasks shown in the Maintenance chapter, you must **not carry out dismantling and assembly operations yourself**. These operations must only be carried out by personnel approved by Virax.
-

Important: Virax may not be held liable for accidents which occur as a result of an unauthorized maintenance operation.

Storage instructions

- Store the machine powered off in a dry place where there is no risk of water or dust spatter, and cover it with a tarpaulin.

General description of the 162120 threading machine

Basic functions

The 162120 threading machine carries out the following three functions:

- cutting tubes
- threading tubes by stock removal
- reaming

Diameters of tubes which can be threaded

The die head supplied with the machine (part no. 162151) can be used to thread tubes with diameters from 1/2" to 2".

Optionally available is a manual die head (part no. 162150) which can be used to thread tubes with diameters from 1/4" to 3/8".

Tubes which can be threaded, cut or reamed

The tubes which can be used on the 162120 are defined by the following standards (refer to the editions published in your language):

1. Stainless steel tubes

EN ISO 1127 June 1996

Stainless steel tubes - Dimensions, tolerances and conventional linear densities

EN 10216-5 March 2005

Seamless steel tubes operating under pressure - Technical delivery conditions
Part 5: Stainless steel tubes

EN 10217-7 August 2005

Welded steel tubes operating under pressure - Technical delivery conditions
Part 7: Stainless steel tubes

2. Carbon steel tubes:

EN 10208-2 October 1996

Steel tubes for carrying combustible fluids - Technical delivery conditions
Part 2: Tubes of specification class B

EN 10216-1 December 2002

Seamless steel tubes operating under pressure - Technical delivery conditions
Part 1: Tubes in unalloyed steel with characteristics specified at ambient temperature

EN 10217-1 December 2002

Welded steel tubes operating under pressure - Technical delivery conditions
Part 1: Tubes in unalloyed steel with characteristics specified at ambient temperature

EN 10255 March 2005

Unalloyed weldable and threadable steel tubes - Technical delivery conditions

Important: not all tubes mentioned in standards prior to standard EN 10255 can be threaded. Depending on diameter, the thicknesses must be greater than or equal to the thicknesses defined by standard EN 10255.

Available thread types

The machine can produce the following thread types:

- with the 2" head
 - BSPT (British Standard Pipe Taper thread)
 - NPT (National standard taper Pipe Thread)
 - Metric
 - BSPP (British Standard Pipe Parallel)
 - BSW (British Standard Whitworth)
 - UNC (Unified National Coarse)
 - NPSM (National Pipe Straight Mechanical)
- with the 3/8" head
 - BSPT
 - BSW

Note: The 2" head is fitted with a BSPT + NPT scale as standard.

Setting the length and outside diameter of the thread

The heads allow the length and outside diameter of the thread to be set.

Option of installing a groover

In addition to the three basic functions (cutting, reaming, threading), the machine can be used with a Virax groover (part no. 162400, available as an option) for hollow tubes in carbon steel with diameters from 1 to 6" and maximum thickness of 3.4 to 5.5 mm in compliance with the standards given on the previous page: EN 10208-2, EN 10216-1, EN 10217-1, EN 10255 W and S:

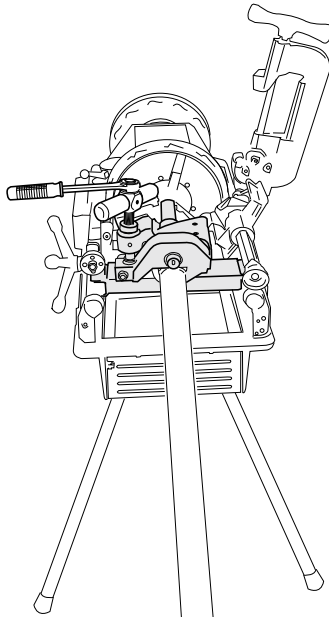

General characteristics

- Power: 1100 W
- Rotational speed: 34 rpm
- Weight of machine only, without mounting feet and without die head: 51.5 kg
- Weight of feet: 6.2 kg
- Weight of 2" die head: 6.6 kg
- Overall dimensions of the machine on its feet
(length x width x height, in mm): 1170 x 705 x 1100
- Acoustic power level: LwA = 92 dB(A)
- Acoustic pressure at the user's ears: LwA = 84 dB(A)
LpMaxPeak < 130 db(C)
- Machine supplied with:
 - 4 feet
 - 1 x 5L drum of cutting oil for steel tubes
 - 1 x 2" automatic die head
 - 1 set of dies, 1/2" - 3/4"
 - 1 set of dies, 1" - 2"
 - 1 set of 2 carbon brushes
 - 1 spare cutter wheel

Moving and setting up the machine

There are three ways of moving the machine:

- by a lifting device such as a hoist or winch
 - manually
 - on the Virax trolley especially designed for the 162120 threading machine (part no. 162160)
-

Important:

- 1) The oil tank must be drained before moving the machine any great distance.
 - 2) Whatever method of transportation is used, the machine must always be transported with a tube clamped between the chucks and the die head, the tube cutter lightly tightened against the tube.
-

Moving by lifting equipment

- Raise the die head (see pages 25 and 28 for the procedure for installing the various heads).



Warning: Do not forget to do this as the die head is simply fixed to its shaft and can therefore fall off during transport.

- Use a 2" tube of sufficient length to overlap the two sides of the machine by about 30 cm.
- Carefully ream each tube end to avoid the tube edges cutting the lifting cable (see page 20 for the reaming procedure).
- Insert the tube into the machine and check that the ends leaving the machine are as equal in length as possible and tighten both chucks. (See page 18 for instructions for mounting a tube):

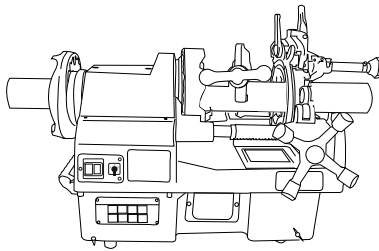

- Place the tube cutter on the tube and tighten it so it is held firmly in place.
- Pass the lifting cable through the tube and move the machine thus carried by the tube. (Once the machine is suspended, you can, if necessary, unscrew the feet to facilitate transport):

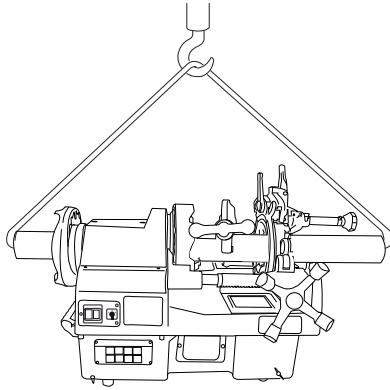

Moving manually

The machine has two transporting handles at each end:

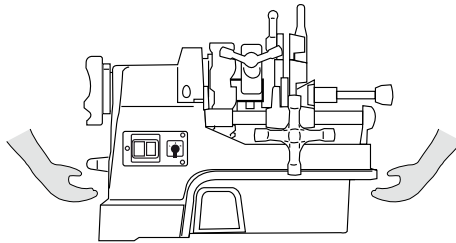

Warning: Two people are needed to raise the machine. Raise and move the machine only by using its handles. (The other parts of the machine do not give a secure grip).

Moving using a trolley

The folding trolley designed by Virax (part no. 162460) enables the 2" machine to be transported and used without setting it back on its feet:

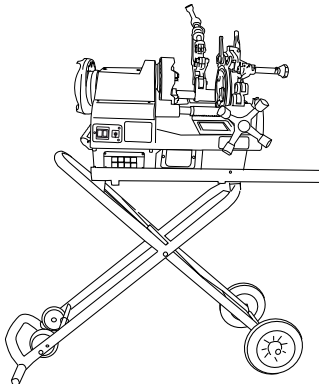

To place the machine on its trolley:

- Remove the retaining hook by depressing the handle using the foot, lift the handle until the trolley is fully unfolded and lock the two retaining levers (levers turned downwards):

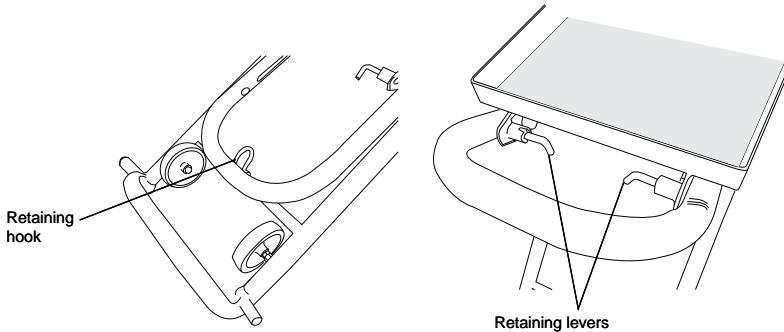

- Place the machine on its support, rear of the machine towards the handle, and fix the retaining screws provided with the trolley.

To transport the trolley with the machine and load it onto a lorry:

- Drain the machine.
- Unlock the two retaining levers (the gas cylinders are designed to support the weight of the machine).
- Lower the trolley handle, fold up the trolley completely, lock the retaining hook (**Warning:** don't forget to do this!) and transport the trolley holding it by its handle.
- Place the front wheels on the edge of the lorry and raise the rear section of the trolley so as to be able to load it fully into the lorry.

Warning:

- 1) Secure the machine firmly to its trolley using the screws supplied whether the machine is being transported or used.
 - 2) The trolley **must not** be used as a platform.
 - 3)  When loading the trolley-machine assembly remember to bend your legs and never lift using the back.
 - 4) When transporting on a lorry, remember to chock the trolley wheels.
-

Slope of the machine

The machine placed on the level on its feet or on its trolley slopes 2° to the front:

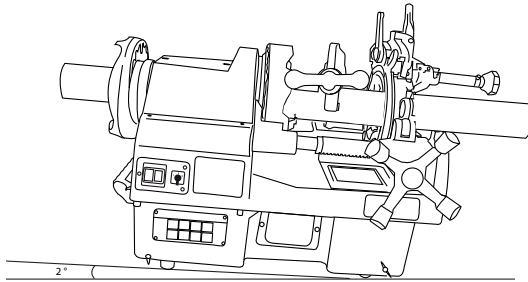

This slope prevents oil flowing towards the back in the tube. Check therefore that this slope is maintained where work is to be carried out.

Be careful to secure the feet firmly to avoid the machine falling.

Positioning a tube

- Open the two chucks sufficiently.
- Insert the tube from the rear, if the working configuration allows this, such that the end of the tube to be machined is level with the tool to be used.
- Centre the tube and tighten the chucks starting with the front chuck.

Note: The front chuck is a hammer chuck: strike several blows towards you (when you are on the operator's side) to tighten the jaws onto the tube.

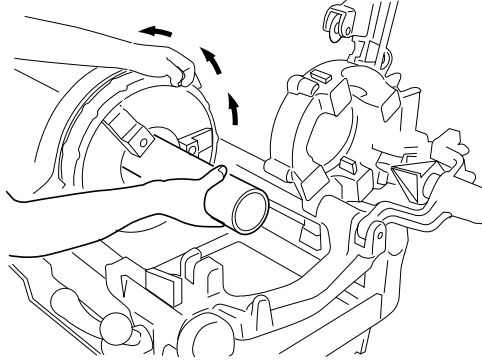

To loosen the chuck, give successive blows in the opposite direction.

Positioning short tubes

- Place the tube in the front chuck and tighten the chuck just so it holds the tube.
- Lower the die head and move the saddle so that the dies come into contact with the tube end:

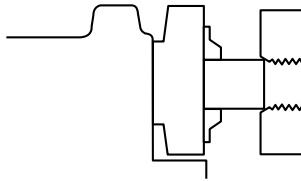

- Use the dies in the die head to centre the tube and tighten the front chuck.

Cutting a tube

The machine has a tube cutter which can cut both carbon steel and stainless steel tubes with diameters varying from 1/4" to 2".

Cutter wheels available:

- Wheel for tubes in carbon steel: part no. 162470 (tubes defined by standards EN 10208-2, EN 10216-1, EN 10217-1 and EN 10255 ; see the description of these standards on page 11)
 - Wheel for tubes in stainless steel: part no. 162471 (tubes defined by standards EN ISO 1127, EN 10216-5, EN 10217-7; see page 11)
- Raise the die head and move the reamer away.
 - Open the tube cutter relative to the tube diameter.
 - Position the tube and tighten both chucks.
 - Start the machine.
 - Lower the tube cutter and tighten it by turning its wheel to the right until the cutter wheel enters the tube:

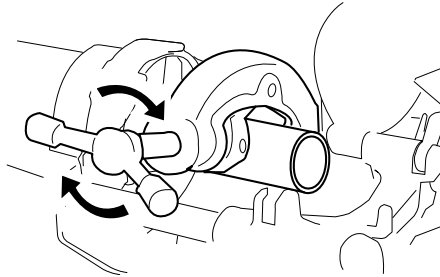

- Turn the tube cutter wheel evenly to the right until the end of the cutting operation. (The wheel must be turned about a quarter of a turn per revolution of the tube).

Important: Turning the wheel too quickly can cause the tube end to become distorted.



Beware of the cut end of the tube falling if the tube protrudes over the front of the machine. Wear protective shoes.

- Stop the motor once the cutting operation is completed.

Reaming a tube

The machine has a reamer for bevelling tube ends with diameters varying from 1/4 to 2".

- Raise the tube cutter and the die head.
- Position the tube and tighten both chucks.
- Move the reaming tool back.
- Push the reaming handle and lock it by turning it fully to the left up to the stop:

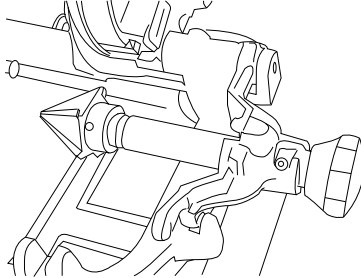

- Start the motor.
- By turning the saddle wheel **to the right**, move the saddle forward so that the reaming cone comes into contact with the tube end.

Note: A plate on the frame gives a reminder that the saddle moves in the opposite direction to the direction of rotation of the wheel: the saddle moves to the left (i.e. towards the front chuck) when you turn the wheel to the right, and vice versa.

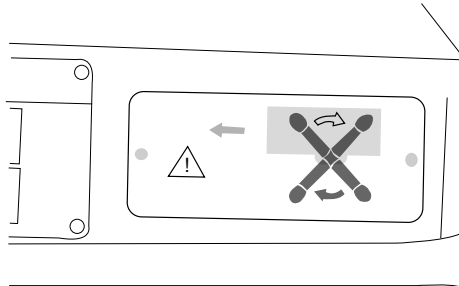

- By applying a light force to the wheel, continue to turn the wheel slowly to the right to obtain a bevel.
- Stop the motor, unlock and remove the reamer handle, loosen the chucks and remove the tube.

Threading a tube

The machine is supplied as standard with a die head for threading tubes with diameters from 1/2" to 2". Optionally available is a head for threading tubes of 1/4" to 3/8" diameter (part no. 162150).

Producing a thread

- Install the appropriate head for the tube diameter (see pages 25 and 28 for the procedures for installing 2" and 1/4 – 3/8" heads).
- Position the tube as indicated on page 18.

Important: Position the tube such that the end to be threaded is **well to the right of the red line** on the front post of the saddle:

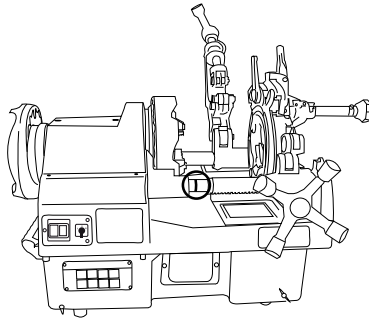

The saddle must not go past this limit: doing this will tear the thread and could even cause the tube to crack.

- Thread: Select position R (R for Right).
- Position L (L for Left) is used to have the motor rotating leftwise.
- To switch direction of rotation à l'autre, it is imperative to hold the switch on the 0 position as long as the motor has not stopped.
- Start the motor. Rotation to the right (R).
- Adjust the oil flow so as to obtain sufficient lubrication and no excess oil. The oil flow regulating wheel is located on the rear panel, right hand side, of the machine:

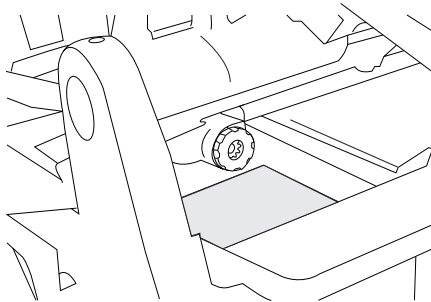

Important: Never cut a thread on a tube without a sufficient oil flow. You risk damaging the tube, the die and the machine.

- By turning the handwheel **to the right**, move the saddle forward so that the dies come into contact with the tube end.

Note: A plate on the frame gives a reminder that the saddle moves in the opposite direction to the direction of rotation of the wheel: the saddle moves to the left (i.e. towards the front chuck) when you turn the wheel to the right, and vice versa.

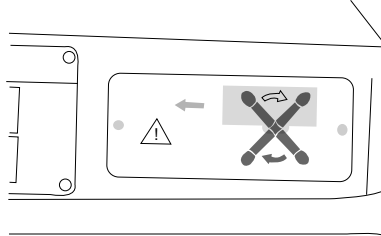

- Turn the wheel slowly to the right applying pressure to enable the die to cut into the tube end.
- When the die has cut 3 or 4 threads, release the wheel and let the saddle move by itself. (You should not accompany the movement of the saddle as this risks making the thread inaccurate).
- When the preset length of the thread is reached, the dies will retract automatically. (The operator has to manually open the 1/4" – 3/8" die head).
- Stop the motor.
- Check that the length of the thread and the outside diameter are sufficient: if a threaded collar or joint is screwed onto the tube, part of the thread must still be visible. Loosen the chucks and remove the tube.

Important: If a thread turns out to be too short, change the length setting and carry out the threading operation again from the start and not from the end of the previous thread. (The joint may seize where the two threads meet).

Producing double threads on short tubes (nipples or reels)

Virax supplies an optional nipple holder which can be used to produce double threads on short tubes with diameters from 1/2" to 2":

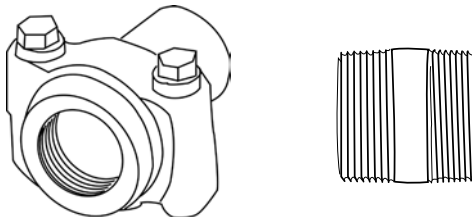

Available diameters:

Nipple holder diameter	Minimum reel length (mm)	Virax part numbers
1/2 "	46	162450
3/4 "	53	162451
1 "	56	162452
1 1/4 "	66	162453
1 1/2 "	66	162454
2 "	73	162455

- Produce the first thread as indicated in the previous paragraph.
- Screw the threaded section fully onto the nipple holder:

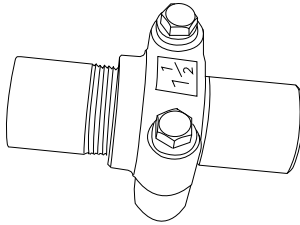

- Clamp the nipple holder in the front chuck:

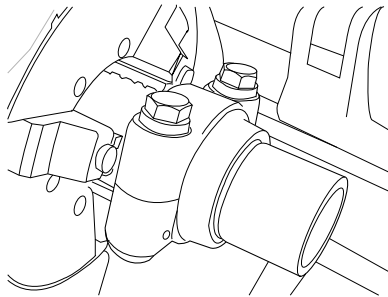

- Cut the second thread:

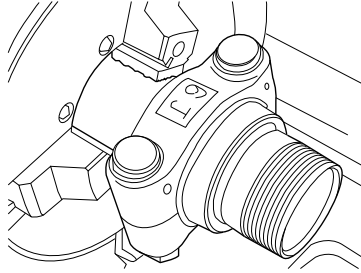

- Remove the nipple holder with the nipple.
- Using a 17mm Allen key, loosen the screws holding the upper shell and remove the nipple.

Important: Release the nipple by loosening the holding shell and not by unscrewing the nipple. (The central section is too narrow to accept pliers. When unscrewing the nipple you would risk damaging the two threads).

Using the 2" die head (Part no. 162151)

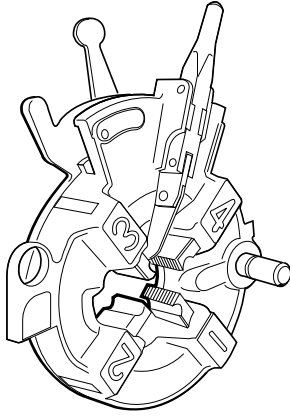

Installing the head

Note: When the machine is delivered, the head is fitted with its dies.

- Position the head tilting spindle in its receiving cylinder:

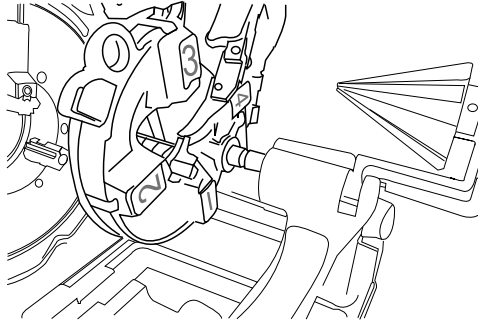

- Tilt the head.

Adjusting the threading diameter

- Loosen the cam plate locking lever by turning it clockwise:

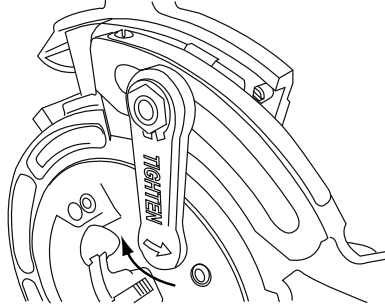

Note: The word "Tighten" is written on the lever accompanied by an arrow pointing anticlockwise. This arrow indicates the tightening direction.

- Holding the setting lever, position the scale such that the indication of the tube diameter is opposite the setting marker:

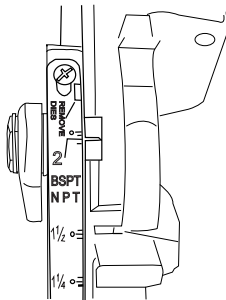

Note: The head is delivered with a scale for BSPT and NPT threads. The BSPT settings are shown by single red lines; the NPT settings are shown by red lines each accompanied by a blue dot.

Adjusting the thread outside diameter

For a given diameter, the markers above the diameter indication enable to increase the thread outside diameter; the markers below the diameter indication enable to reduce the thread outside diameter:

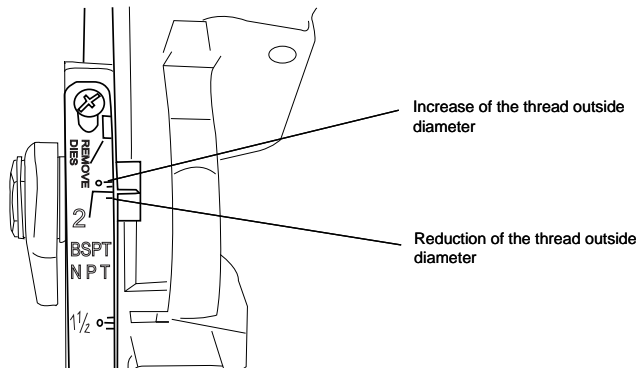

Note: Carry out tests to determine the best setting.

- Tighten the cam retaining lever again by turning it anticlockwise.

Adjusting the thread length

The thread length is adjusted by changing the position of the finger which controls the retraction of the dies.

Note: While cutting the thread, you can open the head by operating the lever.

- Loosen the screw located at the bottom and behind the die retraction lever (6mm Allen key):

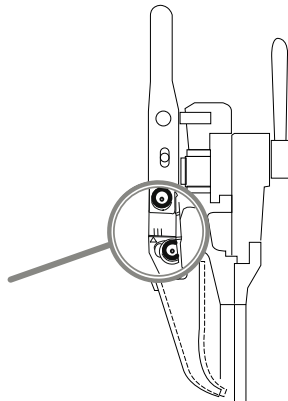

- Position the required line opposite the marker (the leftmost line gives the greatest thread length and the rightmost line gives the shortest thread length).

Using the 1/4 – 3/8" head (part no. 162150)

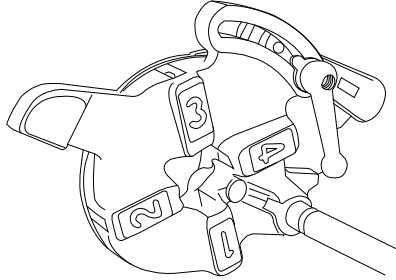

This optional head is used to thread tubes with diameters from 1/4" to 3/8".

Installing the head

Note: When delivered, the head is not fitted with its dies. See page 32 for the procedure for installing dies for the 1/4 – 3/8" head.

- Position the head tilting spindle in the receiving cylinder on the frame:

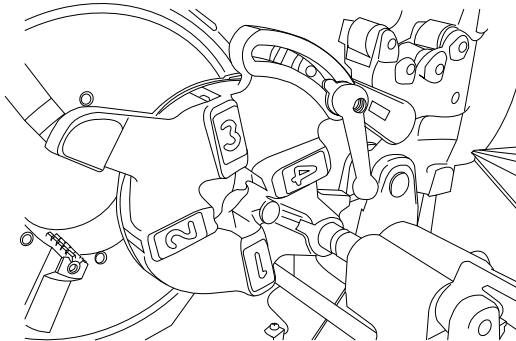

Adjusting the threading diameter

- Loosen the cam bearer plate tightening lever by turning it anticlockwise:

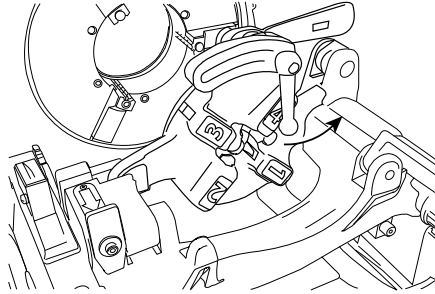

- Position the scale to bring the indication corresponding to the tube diameter up to the marker:

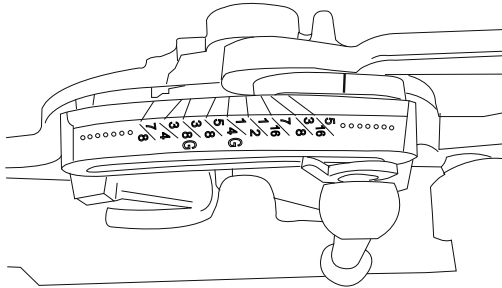

Note: The 1/4 G and 3/8 G markers refer to the BSPT thread standard (G for Gas). The other markers refer to the BSW standard.

Adjusting the thread outside diameter

You can adjust the thread outside diameter by moving the thread scale a short distance in one direction or the other relative to the marker.

Manually opening the dies

When the tube end reaches the tips of the dies, open the dies by moving the die bearer plate lever anticlockwise:

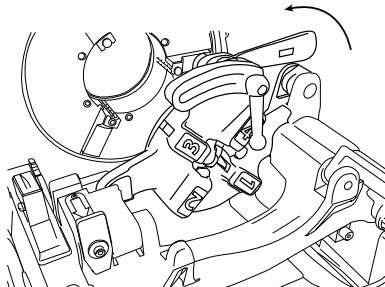

Replacing the dies

Replace the thread dies when the thread loses quality or the turnings become broken up. You should also replace them when you wish to use another thread standard.

Two die types may be used:

- alloy steel dies for cutting threads in carbon steel (see page 11 for the standards defining carbon steel tubes)
- high-speed steel dies for cutting threads in stainless steel tubes (see page 11 for the standards defining stainless steel tubes). These dies are marked “HSS” (for “High Speed Steel”) engraved on the face opposite the die.

Important:

- 1) There are specific dies for each thread standard: BSPT dies, NPT dies, etc. (The thread standard is engraved on the face opposite the die).
Make sure you insert the correct dies for the thread standard you are going to use.
- 2) The four dies must be replaced with four new dies supplied exclusively by Virax.
- 3) The dies are numbered as each die works separately. Ensure that each die is placed in the corresponding socket: die no.1 in socket no. 1, die no.2 in socket no.2, etc.

Note: The die head does not have to be removed in order to replace the dies.

Replacing dies on the automatic opening 2" head

- Firstly retract the dies by operating the opening lever:

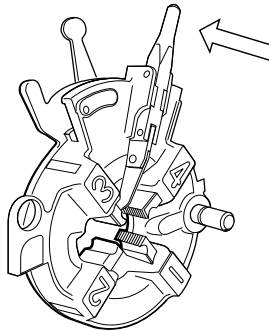

- Loosen the cam bearer plate locking lever by turning it in the reverse direction to that indicated by the arrow:

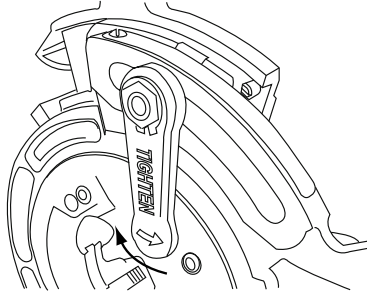

- Holding the setting lever, position the scale such that the indication "Remove dies" is opposite the marker (some force is required):

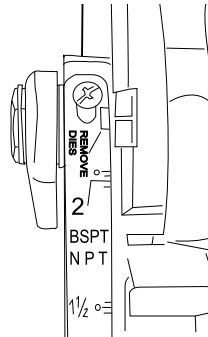

and tighten the locking lever again in order to retain the initial setting of the head.

- Remove the worn dies and loosen the plate slightly.
- Put the new dies in place, notch to the rear, in compliance with the numbering: die no.1 in socket no. 1, die no.2 in socket no.2, etc.:

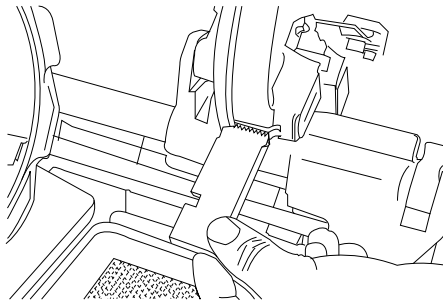

- Insert each die until you can feel that the die is blocked by the ball inside the socket.

Note: The line engraved on the die is used to position the die when it is placed in a manually-opened head. It must not therefore be used as positioning marker with the 2" head.

- Position the setting cam according to the tube diameter and the desired outside thread diameter (see pages 26 and 27).
- Tighten the lever again by turning it in the direction indicated by the arrow.

Replacing dies for the 1/4 – 3/8" head

- Retract the dies by tilting the die bearer plate lever clockwise:

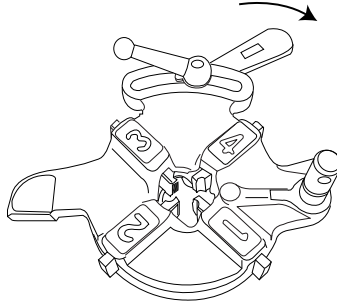

- Unscrew the die bearer plate tightening lever and move the plate to the left as far as the stop:



- Remove the anti-stop finger from its socket and move the plate to the left up to the stop, which frees the dies.

The anti-stop finger of the washer prevents the die bearer plate from moving into the "die freeing" position:

- Remove the dies, in any order. (To remove die no.3, lift the die bearer plate lever).

- Put the new dies in place in compliance with the numbering (die no.1 in socket no. 1, die no.2 in socket no.2, etc.), the notch turned anticlockwise. (Insert each die up to its stop).

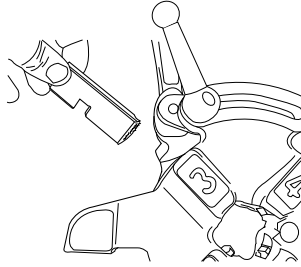

Note: The dies may be inserted in any order.

- Move the die-bearer plate lever to the right which places the cams in the dies:

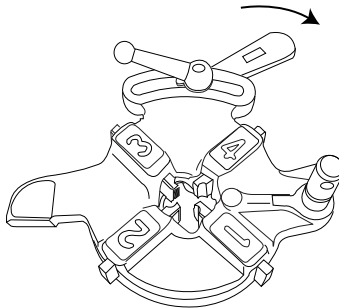

- Position the die bearer plate according to the tube diameter and the desired external thread diameter (see page 29); tighten up the lever.

Maintenance operations

Important: Only the operations described in this chapter are authorized. All other operations must be carried out by personnel approved by Virax.

Cleaning the oil system

- Remove turnings which have accumulated in the receiving bin and clean the scrap receiver.



Warning: Wear gloves when handling turnings (risk of being badly cut).

- Remove the scrap receiver and the oil filter grid and clean the strainer:

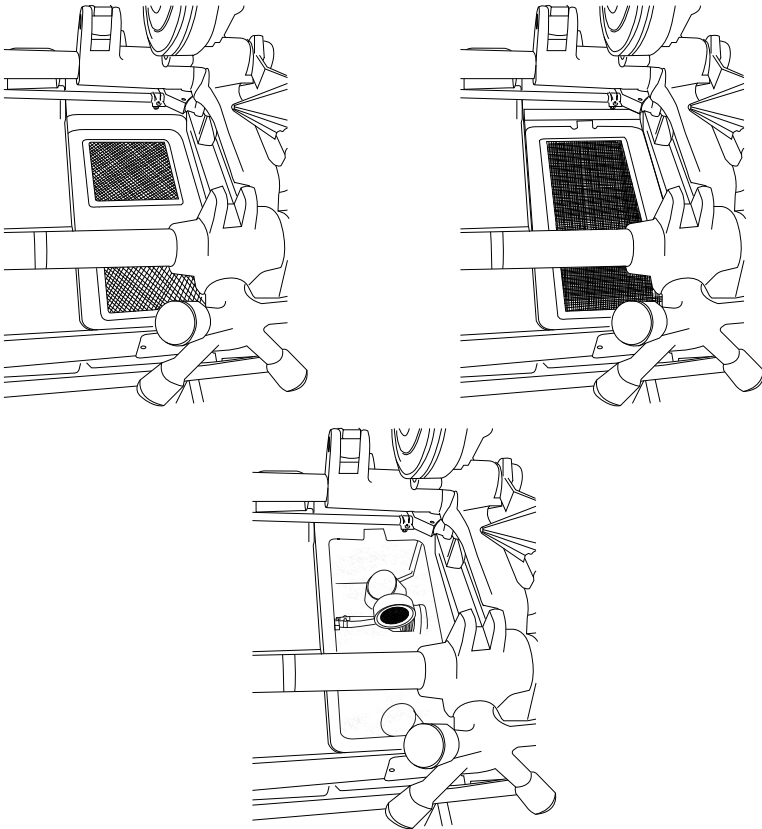

Note: The strainer can also be removed to facilitate cleaning.

- Top up the oil if necessary by pouring it directly into the container. (Minimum oil level: half the diameter of the strainer)

Important: You must use oils supplied by Virax. (See page 9 for the part numbers of the various oils which can be used).

- When the oil loses its clarity, drain it and replace with new oil. The drain plug is located on the front of the machine:

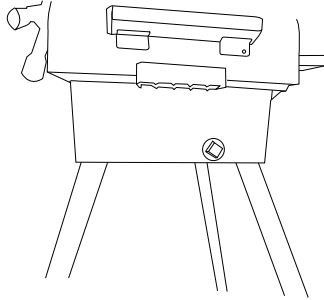

Note: Drain the machine also when it is being transported over any significant distance.

Replacing the motor brushes

The motor will stop working if one of its brushes is worn. Change both brushes.



- Disconnect the machine.
- Remove the protective grids for both brushes. (One grid is located on the operator's side, and the other on the opposite side):

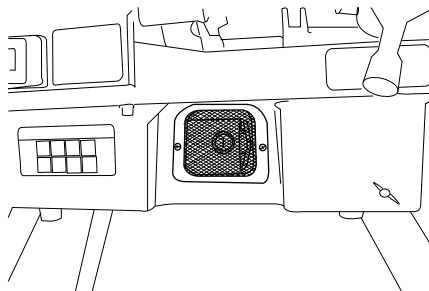

- Remove the protective cover

- Remove the brush from its housing:

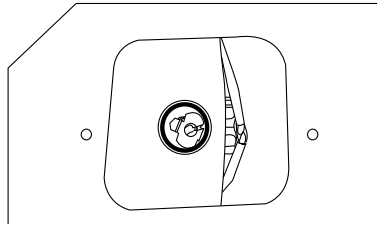

- Replace with a new brush (part no. 753066), replace the protective cover and grid.

Taking up shaft slack

This operation must be carried out if forward and backward play is noted in the motor shaft.

- Tighten up the rear chuck main shaft blind collar using a 5mm spanner until the play disappears:

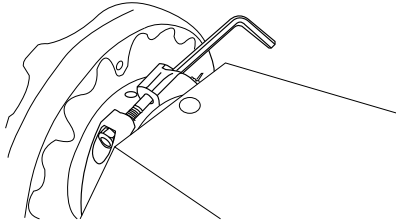

Replacing the cutter wheel

The cutter wheel must be replaced if it shows signs of wear or if you need to cut tubes in a different material.

Two wheels are available depending on the material used for the tube:

- wheel for tubes in carbon steel: part no. 162470
- wheel for tubes in stainless steel: part no. 162471

- Remove the gudgeon wires holding the wheel, replace the wheel and tighten the gudgeon wires again:

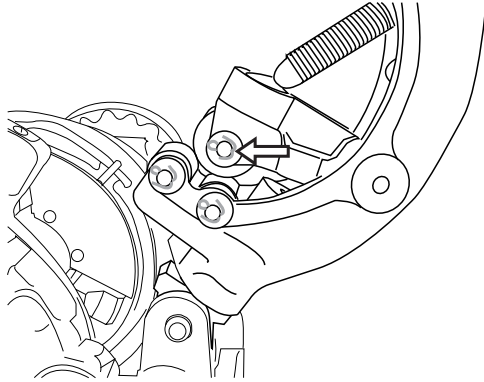

Warning: Do not forget to tighten the gudgeon after replacing the wheel.

Replacing the tube cutter

Replace the tube cutter if it shows signs of cracking or if it is broken.
(Tube cutter for the 162120: part no. 753072)

- Using an 8mm gudgeon punch, remove the tube cutter shaft by striking towards the front of the machine:

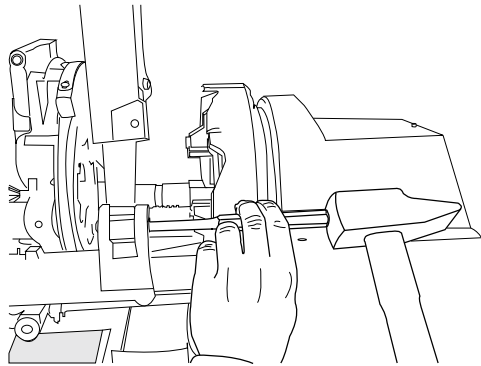

- Remove the tube cutter and replace it with a new one.
- Replace the tube cutter and insert it using the gudgeon punch by striking towards the front of the machine.

Replacing the reaming cone

Replace the reaming cone when it shows signs of wear.
(Reaming cone for the 162120: part no. 753075)

- Remove the gudgeon holding the cone in place using a 5 mm gudgeon punch:

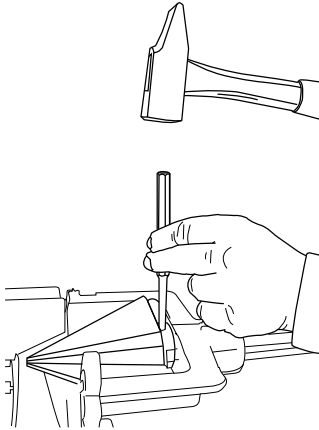

- Remove the cone, replace it with a new one and replace the gudgeon.

Replacing the reamer

The reamer must be replaced if it shows cracking signs of it is broken.
(Complete tool for the 162120: part no. 753074)

- Block the saddle with a wooden block placed between the front chuck and the saddle.
- Remove the gudgeon securing the reamer using an 8mm gudgeon punch.

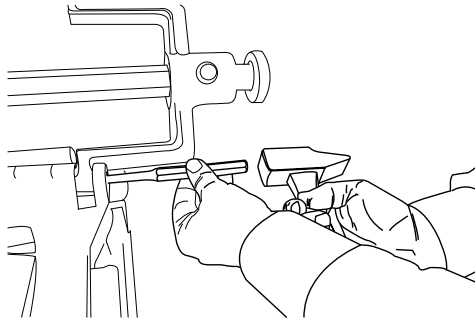

- Put the new reamer in place and reposition the gudgeon.

Replacing the front chuck jaws

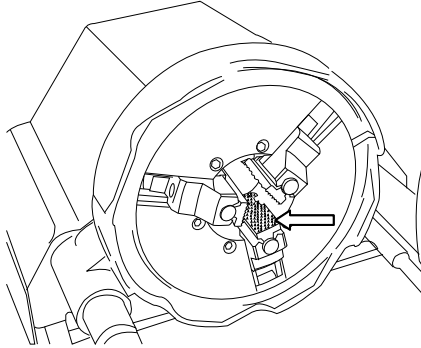

The front chuck jaws must be replaced when they show signs of wear.
(Set of 3 jaws for the 162120: part no. 753069)

Note: The jaw holders do not have to be removed to replace the jaws.

Important: All three jaws must be replaced at the same time.

- Turn the motor over so as to bring the jaw holder whose jaw is to be removed into vertical position, jaw towards the bottom. (Do not try to turn the chuck by hand.)
- Position the chuck groove opposite the jaw holder and insert a 3mm Allen key into the body of the jaw holder:

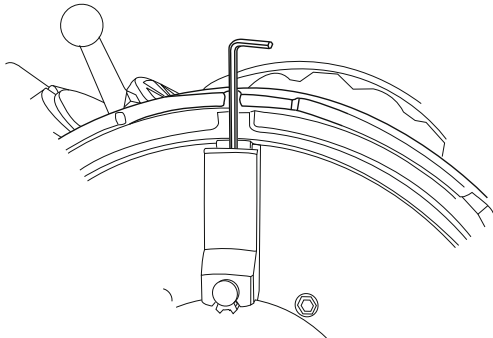

- Use the key to remove the jaw retaining screw.

- Remove the jaw by pulling it towards you and retrieve the associated spring retainer and spring:

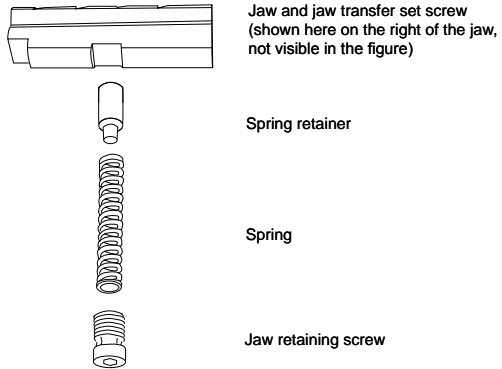

Important: Be careful not to lose the jaw transfer set screw inserted in the side of the jaw.

Replace the jaw and reassemble it, transfer set screw towards the front of the chuck:

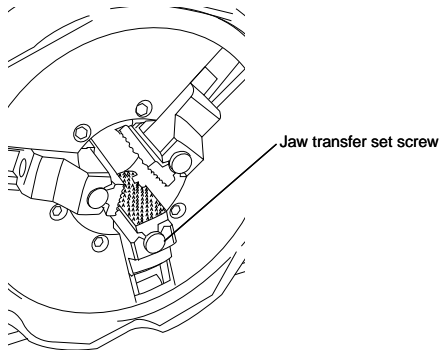

- Replace the spring retainer, spring and screw and tighten the jaw fastening screw.

Replacing the front chuck jaw holders

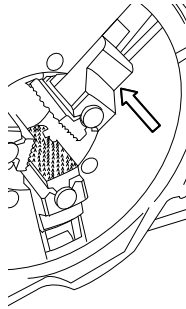

The jaw holders must be replaced when they show signs of wear.
(Jaw holder for the 162120: part no. 753068)

Note:

- 1) *The jaws do not have to be removed to replace the jaw holders.*
- 2) *The jaw holders of the centring chuck (rear chuck) are only subject to slight wear.*
 - Using a 5mm Allen key, unscrew the 6 jaw holding plate screws:

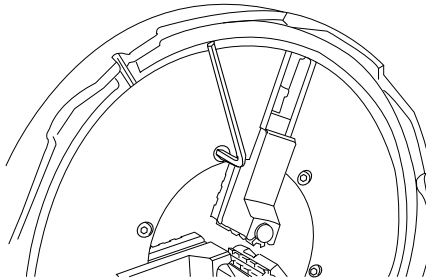

- Dismantle the jaw holding plate - crown assembly (or ask a colleague to hold the crown by the spindle nose while you remove the jaw holder):

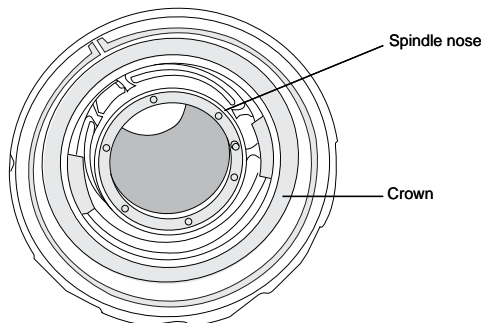

- Put the jaw holding plate down, rear facing upwards, and unscrew the jaw holder helical drive ring:

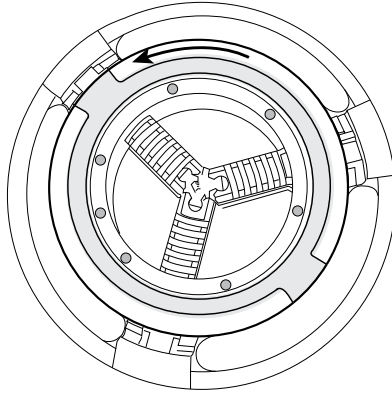

- Turn the jaw holding plate over and remove the three jaw holders:

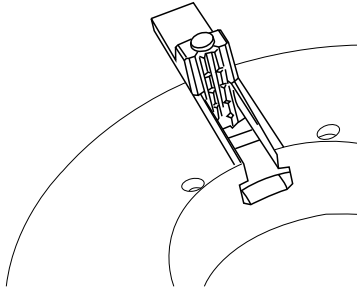

- Put the new jaw holders into their correct numbered locations: jaw holder no. 1 in slot no.1, jaw holder no. 2 in slot no.2 and jaw holder no. 3 in slot no.3.
- Turn the plate with its three jaw holders over. Position the start of the drive ring spiral opposite jaw holder no.1 and insert the jaw holder into the spiral. Turn the ring 120° such that the start of the spiral is opposite jaw holder no.2 and insert the jaw holder. Do the same for jaw holder no.3. Continue to turn the ring until the jaw holders are completely blocked.
- If necessary, replace the chuck crown around the spindle nose and place the jaw holding plate on the spindle nose, lining up the nose pin with the slot on the disc (see figures on the next page).

EN

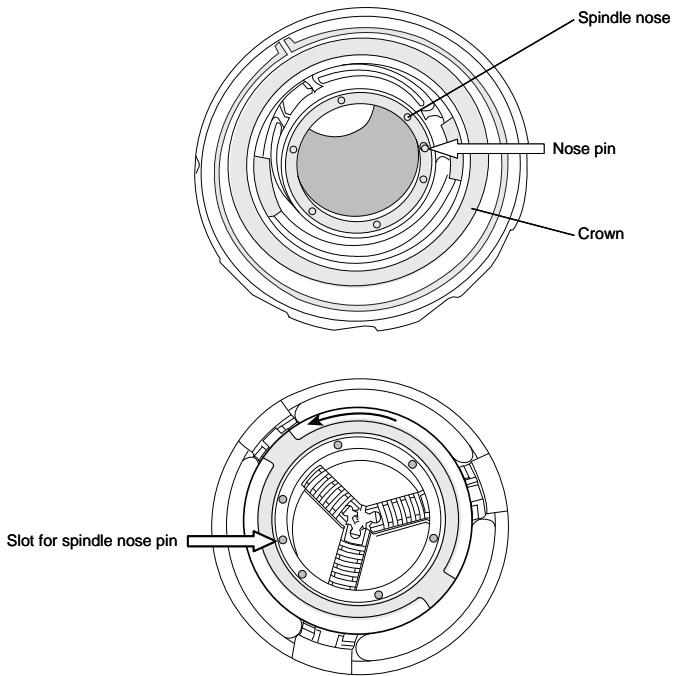

- Screw the jaw holding plate back onto the spindle nose.

Diagnostics and fault fixes

Important: If you encounter problems not on this list, contact Virax or their representative for the problem to be dealt with by After-Sales service.

Machine operating problems

Problem	Possible causes	Corrective actions
The motor does not operate when the start button is pressed.	The power socket is not connected to the electrical power supply.	Connect the socket to the electrical power supply.
	The power supply voltage is too low.	Check the voltage delivered by the electrical power supply. (The voltage must not be less than 150 V).
	The motor brushes are worn.	Replace the brushes by new ones (see page 35).
	The start button is not working.	Replace the button. (Warning: do not short circuit the start button; see page 8, "Attention", concerning the machine being restarted after an unexpected stop).
	The motor is burnt out.	Contact Virax or their representative to change the motor.
The machine shaft is not driven by the motor.	The transmission is broken.	Contact Virax or their representative to change the transmission.
The shaft rotation is slow or irregular.	The power supply voltage is too low.	Check the supply voltage. (It must not be less than 150 V).
	The transmission is defective.	Contact Virax or their representative to change the transmission.
There is forward and backward play in the motor spindle.	The rear chuck retaining collar is not sufficiently tight.	Tighten up the main shaft blind collar. (See page 36).

Problem	Possible causes	Corrective actions
The tube is not held sufficiently by the front chuck.	The front chuck jaws are worn.	Replace the three jaws of the front chuck. (See page 39).
	The front chuck jaw holders are worn.	Replace the three jaw holders of the front chuck. (See page 41).

Thread cutting problems

Problem	Possible causes	Corrective actions
The die head is hard to insert correctly.	The head tilting spindle or the receiving cylinder are fouled.	Clean the spindle and the receiving cylinder.
The oil flow in the head is insufficient.	The flow is badly regulated.	Increase the oil flow by turning the flow regulating wheel. (See page 21).
	The oil system is fouled.	Remove turnings from the scrap receiver and the oil filter grid and clean the strainer. (See page 34).
	The oil level is insufficient.	Add oil supplied by Virax (see page 9) by pouring it directly into the container. (Minimum oil level: half the diameter of the strainer).
The oil is no longer clear.	The oil has been in use for too long.	Drain the oil (see page 35) and refill with oil supplied by Virax (see page 9).
The oil flows out the back of the tube.	The machine is not sloped forward by the correct amount.	Position the machine on the horizontal so that the 2° slope is maintained. (See page 17).

Problem	Possible causes	Corrective actions
The dies do not enter the tubes sufficiently.	The dies are fouled.	Clean the ends of the dies with a metal brush.
	The dies are worn.	Replace the four dies by new ones. (See page 30 for the 2" head, and page 32 for the 1/4 – 3/8" head).
	The die numbering has not been complied with.	Remove the dies and replace them (see page 30 for the 2" head, and page 32 for the 1/4 – 3/8" head) and ensure the numbering of the dies is complied with: die no.1 in socket no. 1, die no.2 in socket no.2, etc.
The quality of the thread obtained is not satisfactory.	Same reasons as above: dies fouled or worn, or die numbering not complied with.	See above.
	Oil worn out	Drain the oil (see page 35) and refill with oil supplied by Virax (see page 9).
The thread is not deep enough or is too deep.	The outside diameter of the thread has not been set correctly.	Adjust the thread diameter so as to obtain the expected result. (See page 27 for the 2" head, and page 29 for the 1/4 – 3/8" head).
With the 2" head, the thread is too long or too short	The thread length has not been set correctly.	Adjust the thread length so as to obtain the expected result. (See page 27).

Tube cutting problems

The cut obtained is not clean.	The cutter wheel is worn.	Replace the cutter wheel by a new one. (See page 36).
The tube cutter is damaged.	The tube cutter is worn or has been used for tubes which are too hard.	Replace the tube cutter by a new one. (See page 37). Use the tube cutter on carbon steel or stainless steel tubes.

Reaming problems

Reaming is not satisfactory.	The reaming cone is worn.	Replace the cone by a new one. (See page 38).
The reamer is damaged.	The reamer is worn or has been used for tubes which are too hard.	Replace the reamer by a new one. (See page 38). Use the reamer on carbon steel or stainless steel tubes.

Exploded views

If you need a particular part, please indicate the title of the exploded view as well as the number of the part on this view.

Exploded view of the frame

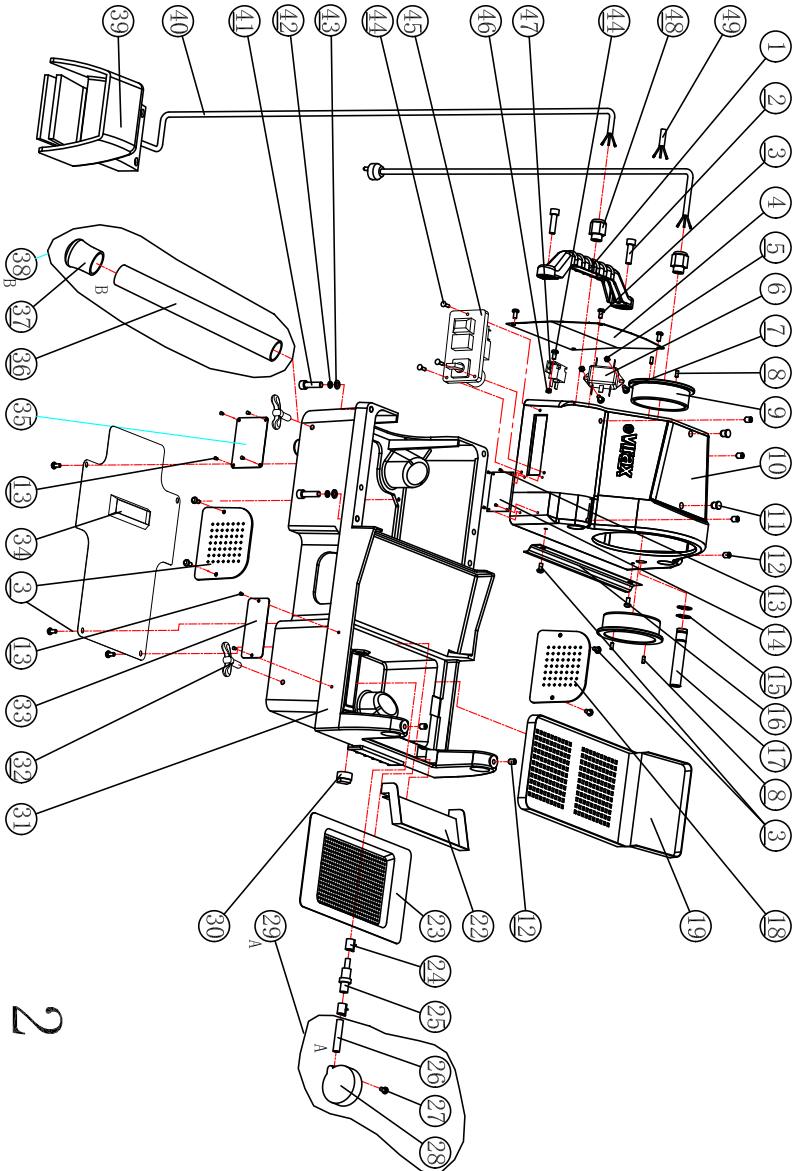

Exploded view of the motor and the oil pump

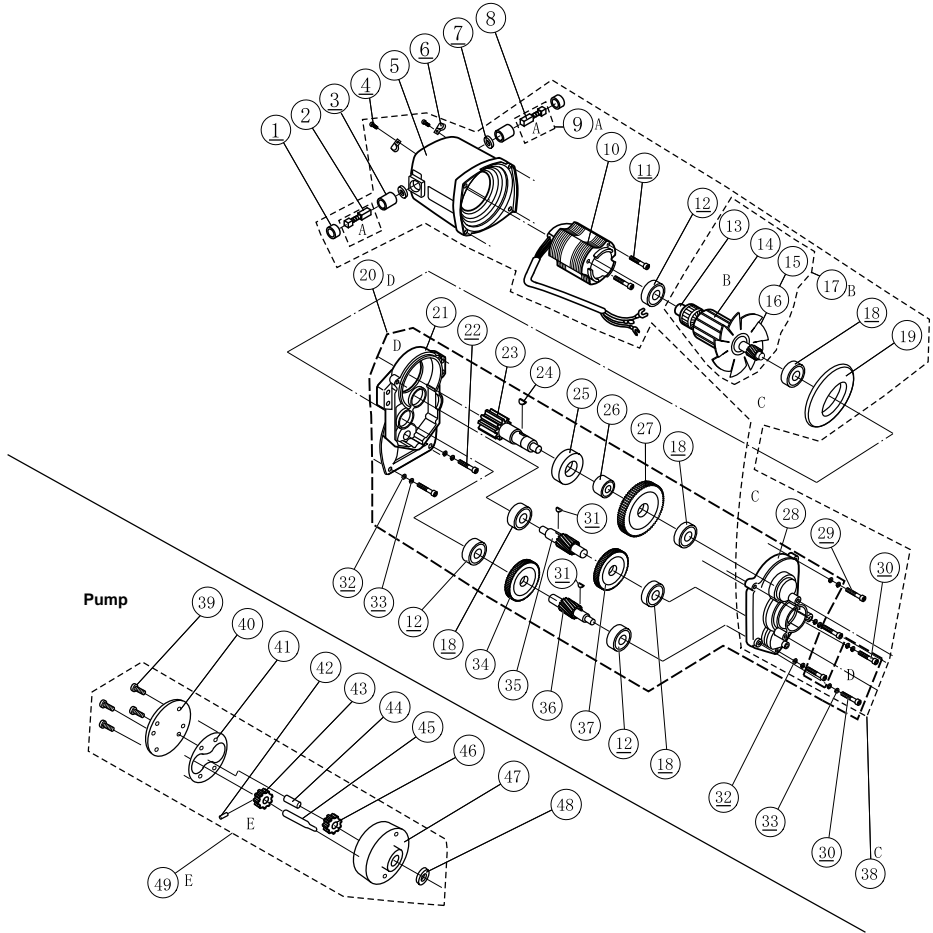

Exploded view of the transmission

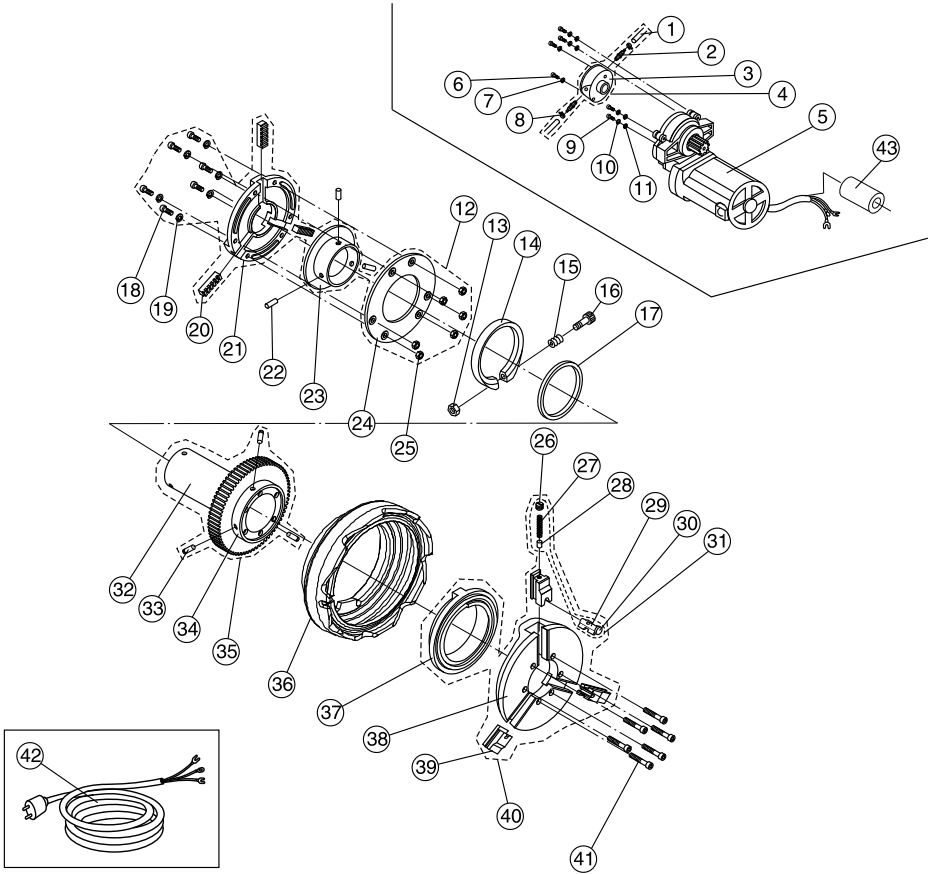

Exploded view of the saddle

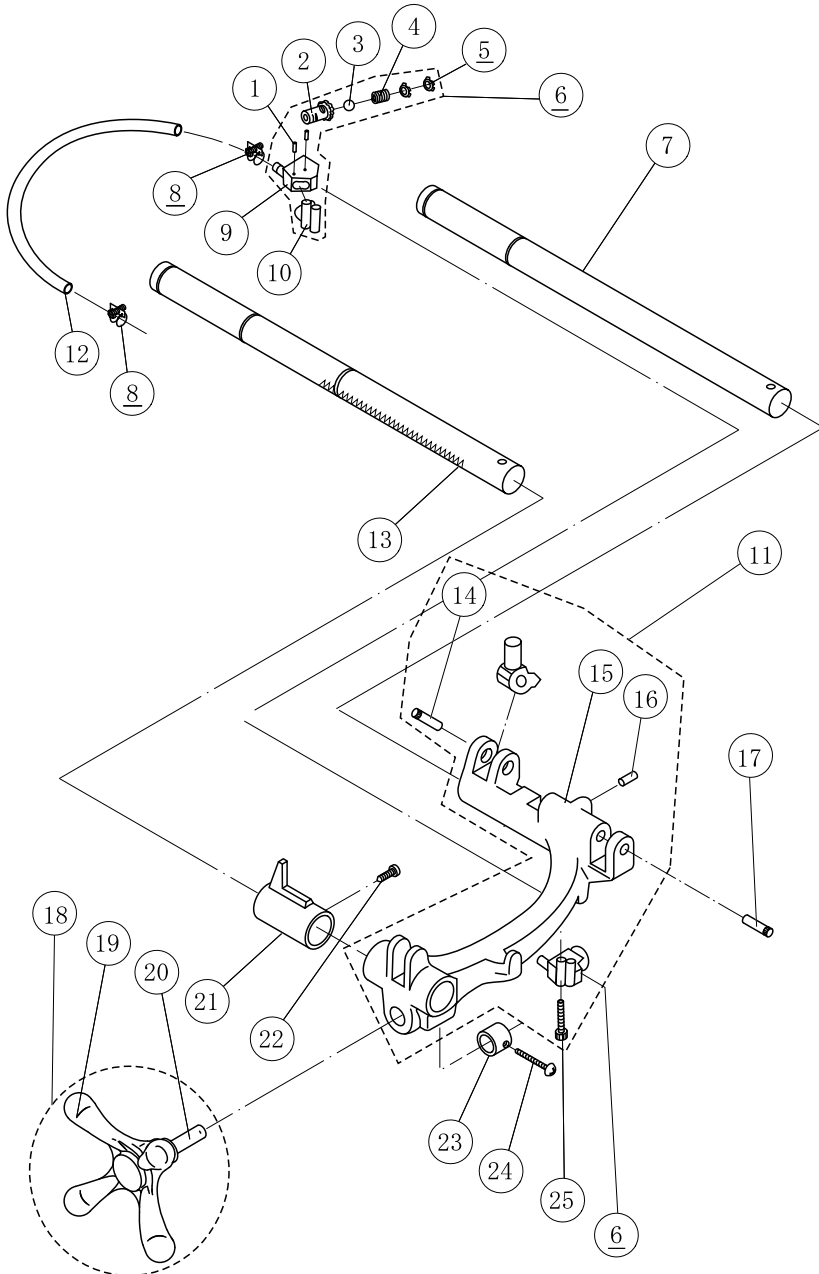

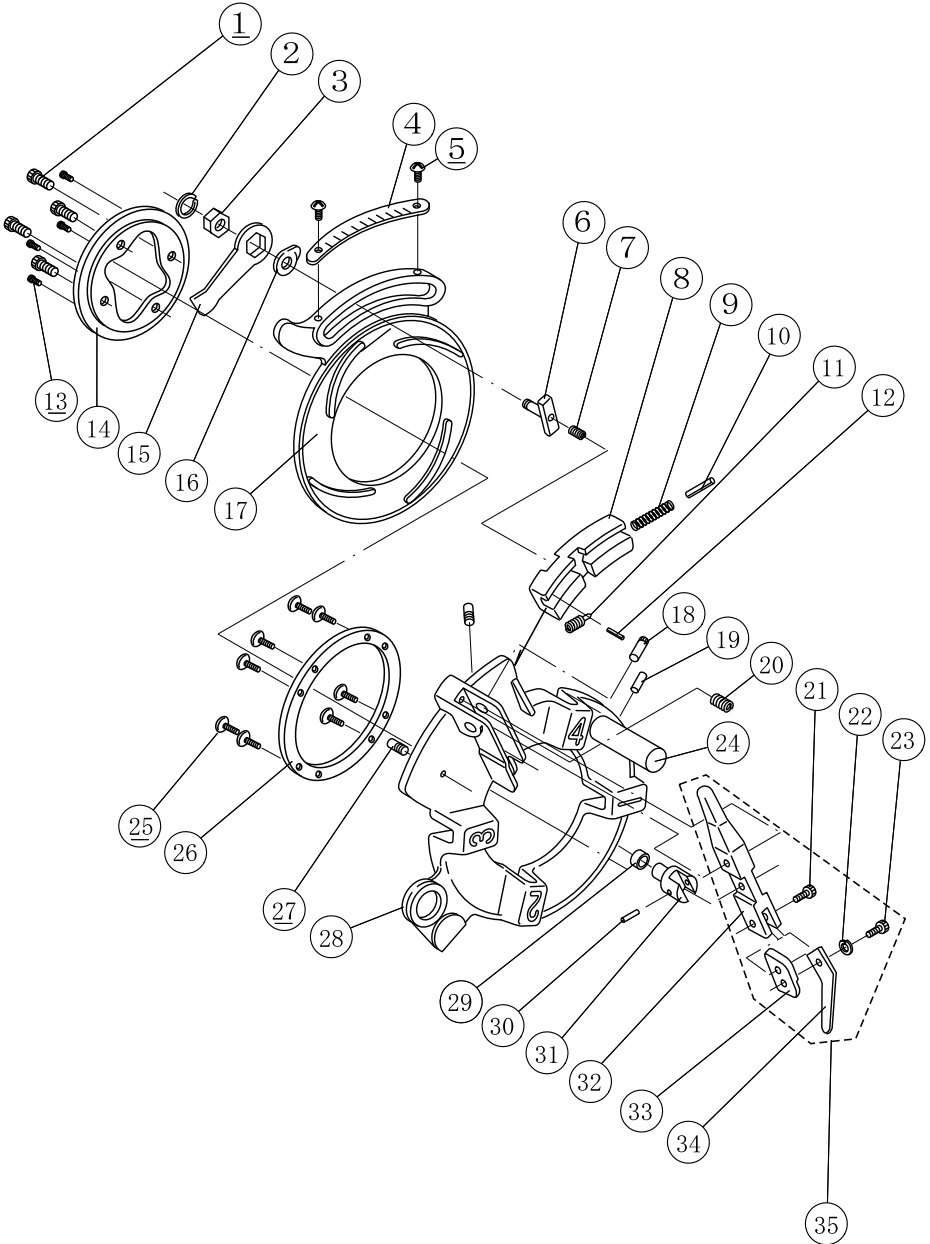
Exploded view of the automatic opening 2" die head

Exploded view of the 1/4" - 3/8" die head

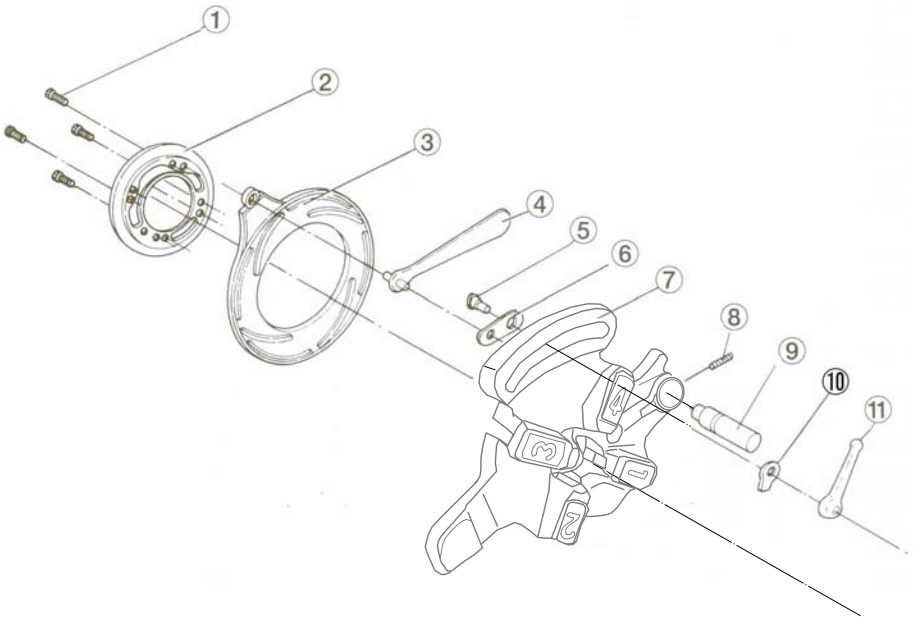

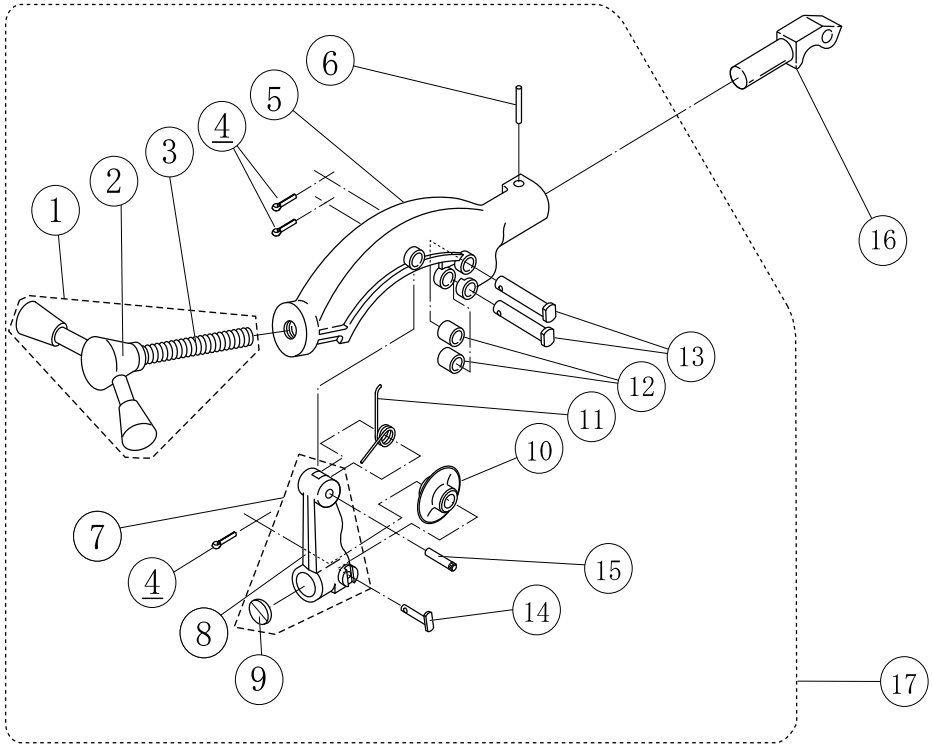
Exploded view of the tube cutter

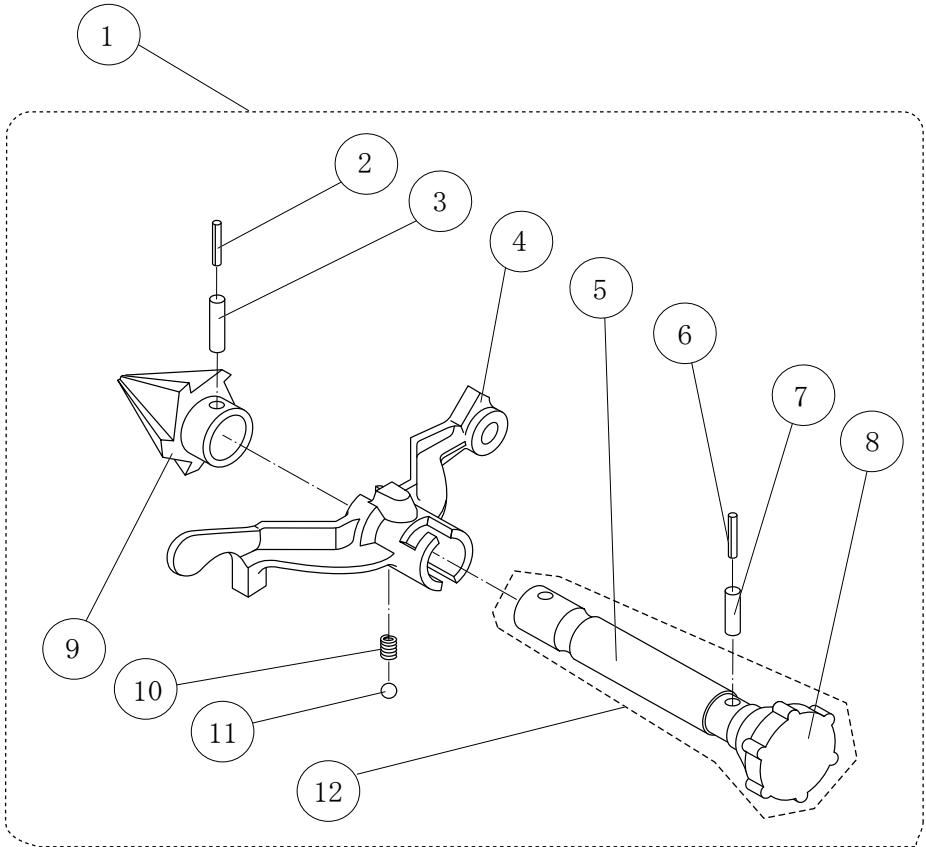
Exploded view of the reamer

Components of a nipple holder

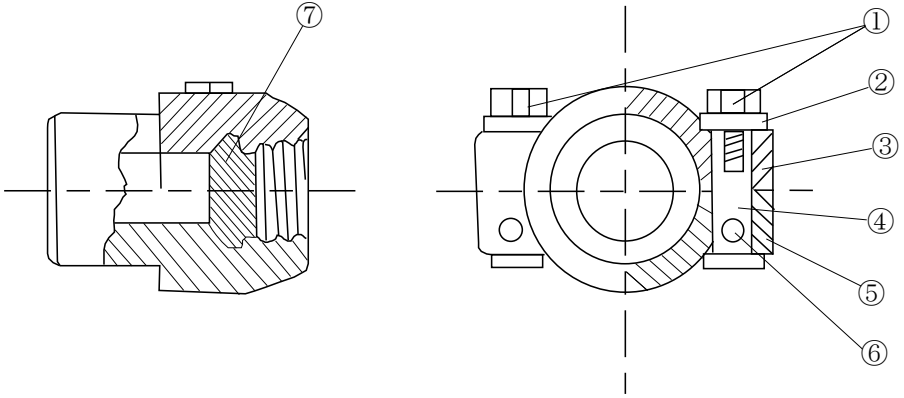



FR- Retrouvez la liste de nos distributeurs sur www.virax.com

EN – Find the list of our dealers on www.virax.com

IT – Trova il rivenditore Virax più vicino a te su www.virax.com

ES - Encuentra el listado de distribuidores en www.virax.com

PT - Encontre a lista de nossos revendedores www.virax.com

NL - Vind de lijst van onze resellers www.virax.com

EL - Συμβουλευτείτε τη λίστα των διανομέων μας στο www.virax.com

PL - Listę naszych dystrybutorów znajdziecie na www.virax.com

DE - Eine aktuelle Liste unserer Handelspartner finden Sie unter www.virax.com

CS - Seznam našich prodejců najdete na www.virax.com

RU - Список дилеров вы можете найти на сайте www.virax.com

TR - Distribütör' lerimizin listesini, www.virax.com web sitemizden bulabilirsiniz

عربية - www.virax.com يمكنك الحصول على قائمة الموزعين الرسميين على الموقع